

HI-PERF RIDGE VENT

SLOPE TO SLOPE, STANDING SEAM VERSION

INSTALLATION INSTRUCTIONS

U.S. PATENT # 8,075,376 B1

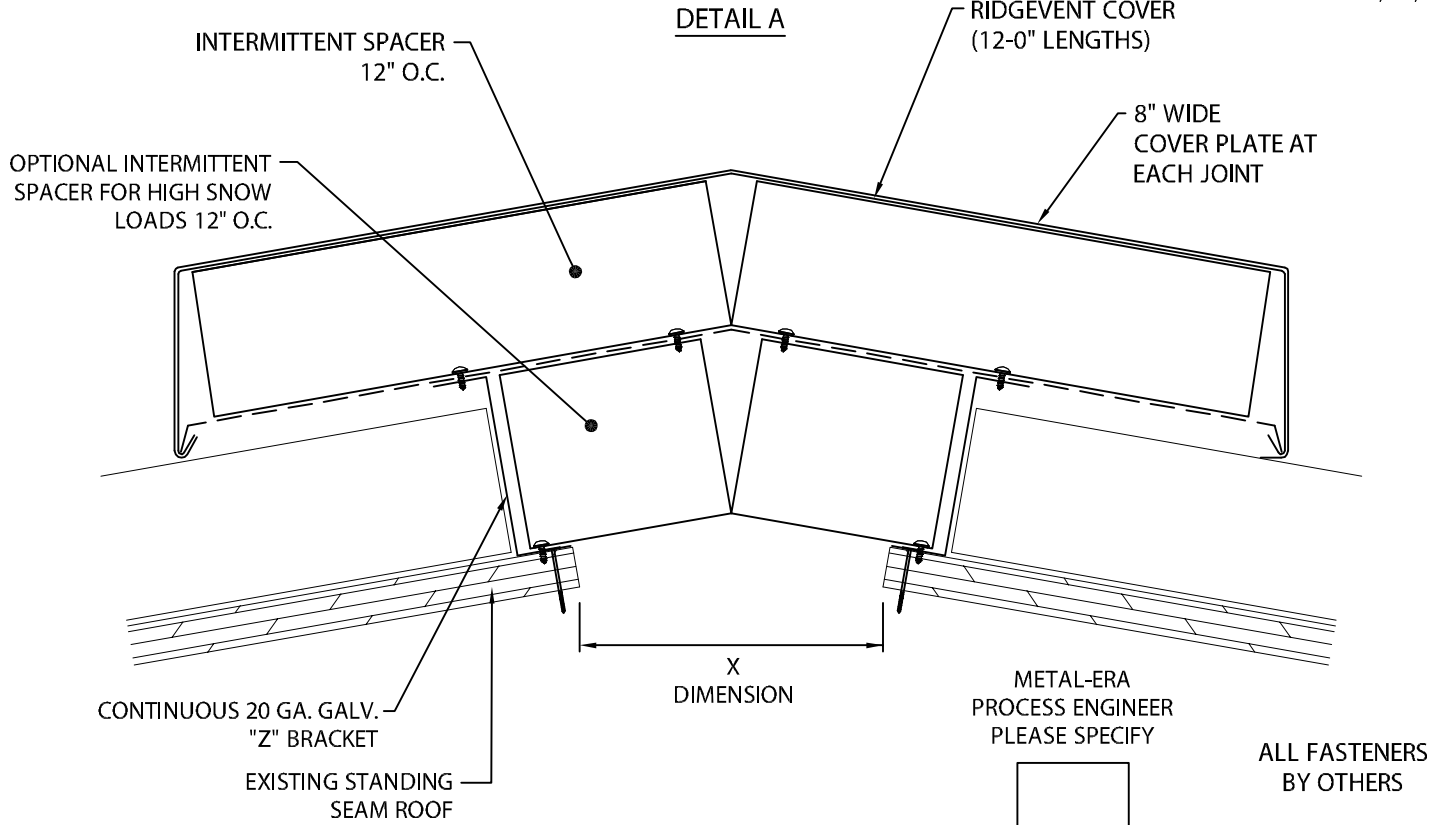

CAUTION! INSTALLERS SHALL WEAR PROTECTIVE EYE WEAR TO PREVENT INJURY. DO NOT OVERDRIVE FASTENERS, AS STRIPPING CAN OCCUR AT HIGH DRIVER TORQUE. RECOMMENDED DRIVING TOOL: 600 - 800 rpm ELECTRIC DRILL EQUIPPED WITH DEPTH-SENSING NOSE-PIECE TO PREVENT DRIVING AND STRIPOUT. DO NOT USE IMPACT TYPE TOOL.

IMPORTANT! BE SURE TO REMOVE PROTECTIVE PLASTIC FILM PRIOR TO INSTALLING EACH COVER SECTION.

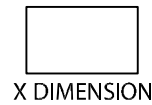

NOTE: ALL FASTENERS MUST MEET MINIMUM 240 LB. PULL-OUT FOR SUBSTRATE.

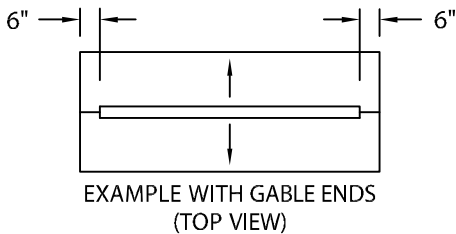

1. PREPARE RIDGE

CUT OPENING AT RIDGE "X" DIMENSION. END THE OPENING 6" BEFORE GABLE OR HIPPED END.

		Phone: 800-558-2162 Fax: 800-770-3934 www.metalera.com	
		DATE: 03/10/16	SHT.# <u>1</u> OF <u>4</u>
DRN BY: JJC		DWG# 31124-14311 F	
CKD BY: SAK			

HI-PERF RIDGE VENT

SLOPE TO SLOPE, STANDING SEAM VERSION

INSTALLATION INSTRUCTIONS

U.S. PATENT # 8,075,376 B1

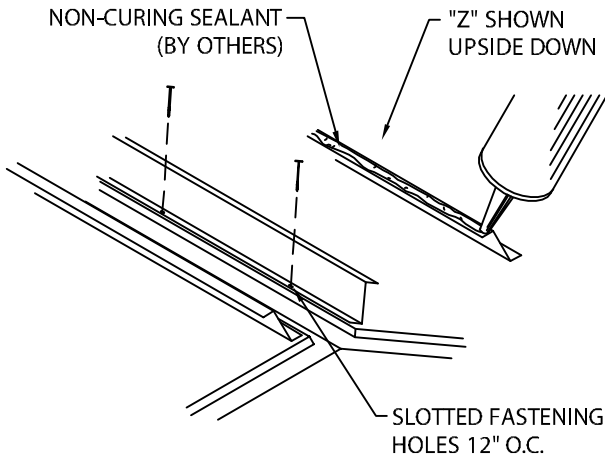

2. MOUNTING BRACKETS

TO PREVENT MOISTURE ENTRY UNDER THE "Z", APPLY A GENEROUS BEAD OF NON-CURING SEALANT (BY OTHERS) TO BOTTOM OF FLANGE. FASTEN BRACKETS AT ROOF AT 12" O.C. WITH APPROPRIATE FASTENERS USING PRE-PUNCHED SLOTTED HOLES. LAP "Z'S" 1".

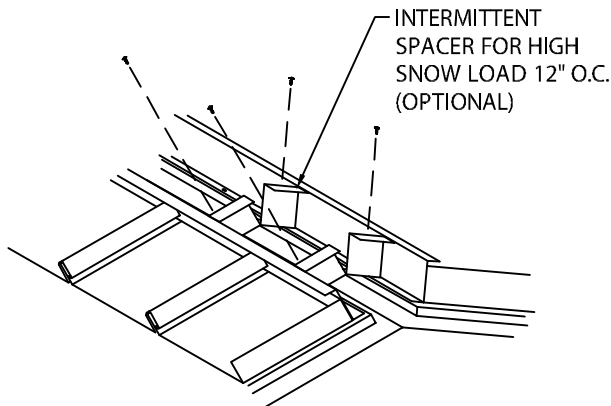

4. INTERMITTENT SPACER (OPTIONAL SNOW BRACE)

TO PREVENT COLLAPSE IN HIGH SNOW LOAD AREAS, FASTEN OPTIONAL INTERMITTENT SPACER 12" O.C. AS SHOWN WITH APPROPRIATE FASTENERS.

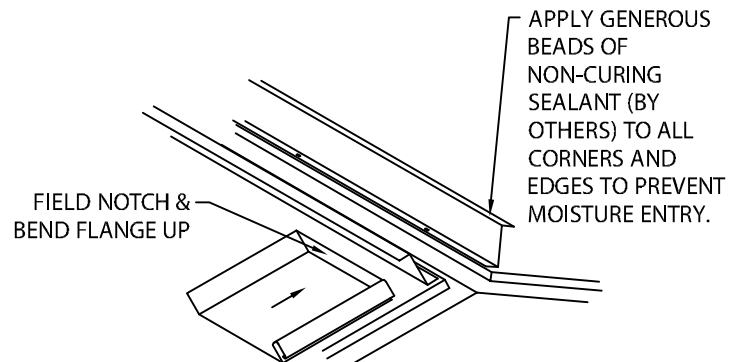

3. STANDING SEAM ROOFING

FOLLOW MANUFACTURER'S RECOMMENDATIONS FOR TERMINATING STANDING SEAM AT RIDGE VENT CHANNEL. SEE ABOVE FOR TYPICAL DETAIL.

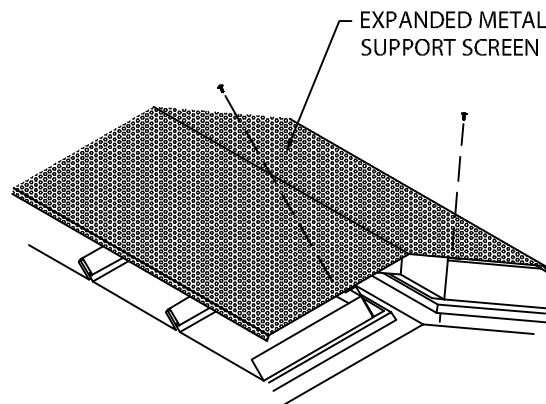

5. EXPANDED METAL SUPPORT SCREEN

PLACE ONE SCREEN CENTERED OVER BRACKETS. TEMPORARILY FASTEN TO "Z" BRACKETS AT BOTH ENDS OF 12'-0" SCREEN (FOUR FASTENERS TOTAL). IN ORDER TO MINIMIZE THE LENGTH OF SCREEN AND SPACERS THAT THE COVER WILL SLIDE ONTO, START BY INSTALLING TWO LENGTHS OF SCREEN (LAP SCREENS 1") WITH THE APPROPRIATE INTERMITTENT SPACERS (SPACER INSTALLATION, STEP 7) AFTER ENDCAP IS INSTALLED (STEP 9) SLIDE FIRST COVER INTO PLACE. FROM THERE INSTALL ONE SCREEN AND APPROPRIATE SPACERS AND IMMEDIATELY SLIDE ON ONE COVER.



Phone: 800-558-2162
 Fax: 800-770-3934
www.metalera.com

DATE: 03/10/16

SHT.# 2 OF 4

DRN BY: JJC

CKD BY: SAK

DWG# 31124-14311

F

HI-PERF RIDGE VENT

SLOPE TO SLOPE, STANDING SEAM VERSION

INSTALLATION INSTRUCTIONS

U.S. PATENT # 8,075,376 B1

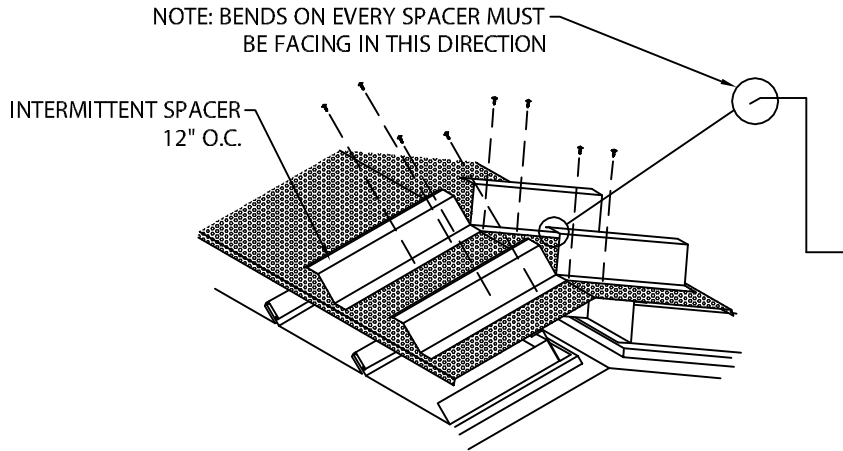

6. INTERMITTENT SPACERS

STARTING AT THE END OF THE ROOF WHERE THE ENDCAPS WILL BE PLACED, FASTEN INTERMITTENT SPACERS 12" O.C. AS SHOWN WITH APPROPRIATE FASTENERS. THE BENDS ON TOP OF THE SPACER MUST ALL BE FACING AWAY FROM THE END OF THE ROOF.

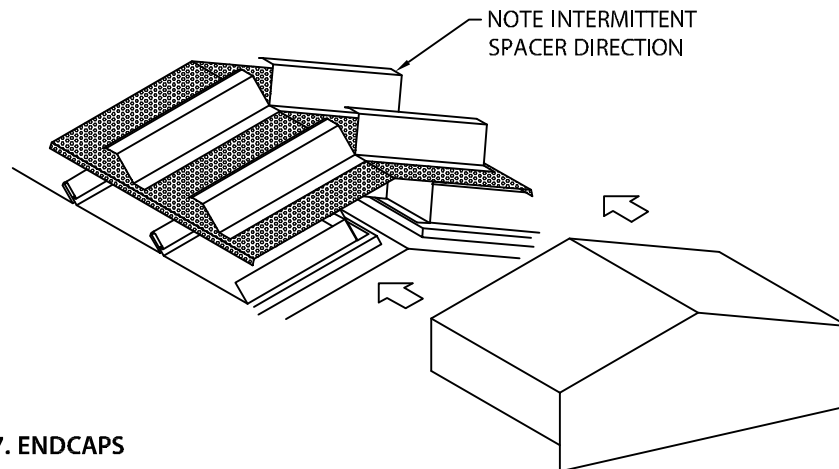

7. ENDCAPS

SLIDE ENDCAP ONTO EXPANDED METAL SUPPORT SCREEN. REMOVE PROTECTIVE FILM IMMEDIATELY.



Phone: 800-558-2162
Fax: 800-770-3934
www.metalera.com

DATE: 03/10/16

SHT.# 3 OF 4

DRN BY: JJC

CKD BY: SAK

DWG# 31124-14311

F

HI-PERF RIDGE VENT

SLOPE TO SLOPE, STANDING SEAM VERSION

INSTALLATION INSTRUCTIONS

U.S. PATENT # 8,075,376 B1

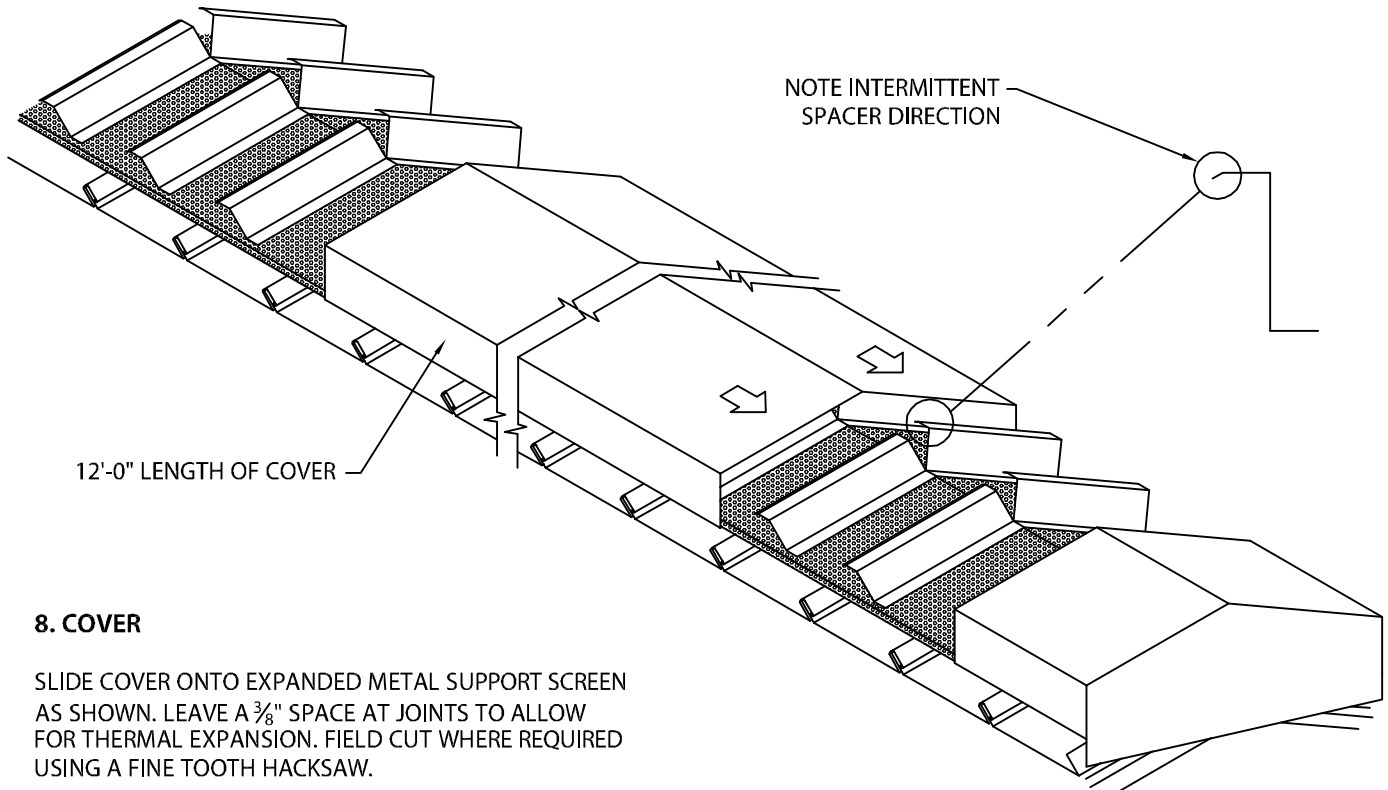

8. COVER

SLIDE COVER ONTO EXPANDED METAL SUPPORT SCREEN AS SHOWN. LEAVE A $\frac{3}{8}$ " SPACE AT JOINTS TO ALLOW FOR THERMAL EXPANSION. FIELD CUT WHERE REQUIRED USING A FINE TOOTH HACKSAW.

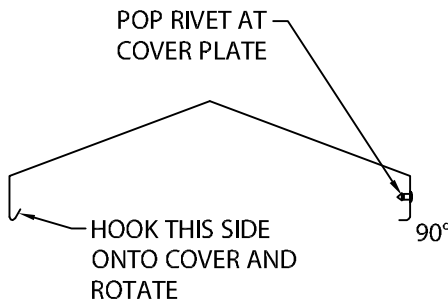

9. COVER PLATES AT JOINTS

APPLY A GENEROUS BEAD OF NON-CURING SEALANT (BY OTHERS) TO EACH SIDE OF JOINT. HOOK COVER PLATE ONTO COVER AT JOINTS AND ROTATE INTO PLACE. POP RIVET INTO COVER PLATE AT ONE SIDE OF THE JOINT (FASTEN SIDE WHICH HAS 90° DRIP ANGLE). THIS WILL PREVENT MIGRATION.

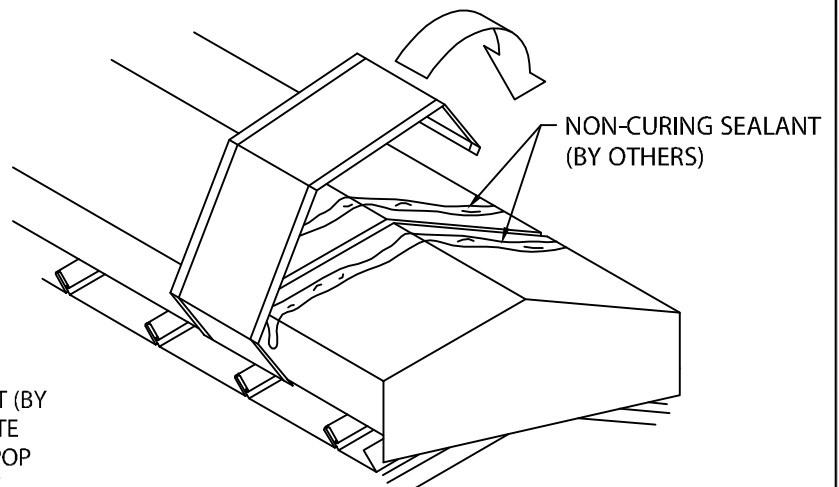

Phone: 800-558-2162
 Fax: 800-770-3934
 www.metalera.com

DATE: 03/10/16

SHT.# 4 OF 4

DRN BY: JJC

CKD BY: SAK

DWG# 31124-14311

F